

Bat boxes come in many shapes and sizes, however this design by Peter Chapman ( *Vincent Wildlife Trust* ) with its bottom opening flap is approved by the Devon Bat Group and used extensively throughout the County. Boxes should be made from rough sawn soft wood to allow bats grip when roosting. No wood preservatives should be used as these may be harmful to bats.

### **Location**

Boxes should be placed as high as practical, usually three placed around each tree giving the bats a choice of roosting conditions. Woodland rides and glades are ideal particularly if close to ponds or rivers, this provides suitable roost sites within easy reach of their food source, bats feed predominantly on flying insects.

### **Fixing**

The box can be secured to the trunk using 75mm copper or aluminium alloy nails, these will not harm the tree and ensure no damage occurs to cutting machinery at a later date. As the tree grows the boxes are sometimes pushed off, these can be relocated during annual checks.

### **Checking your boxes**

Bats and their roosts are fully protected under the Wildlife and Countryside Act 1981, this makes it an offence (without a licence) to disturb roosting bats. A careful check for bat droppings on the ledge below the entrance will indicate if the box has been used, this can be followed up by surveillance at dusk to watch for emerging bats. Sometimes birds and mice use bat boxes so September is the ideal time to make an annual check and clear out any old nests and debris. Dormice sometimes use bat boxes and can be present at this time. Like bats, they are also protected and should not be handled or evicted.

### **Further information**

Contact the Devon Bat Group

Tel/Fax 01409 231364

Produced by David F Wills for the Devon Bat Group. 2001.



# GUIDE TO MAKING YOUR OWN BAT BOXES

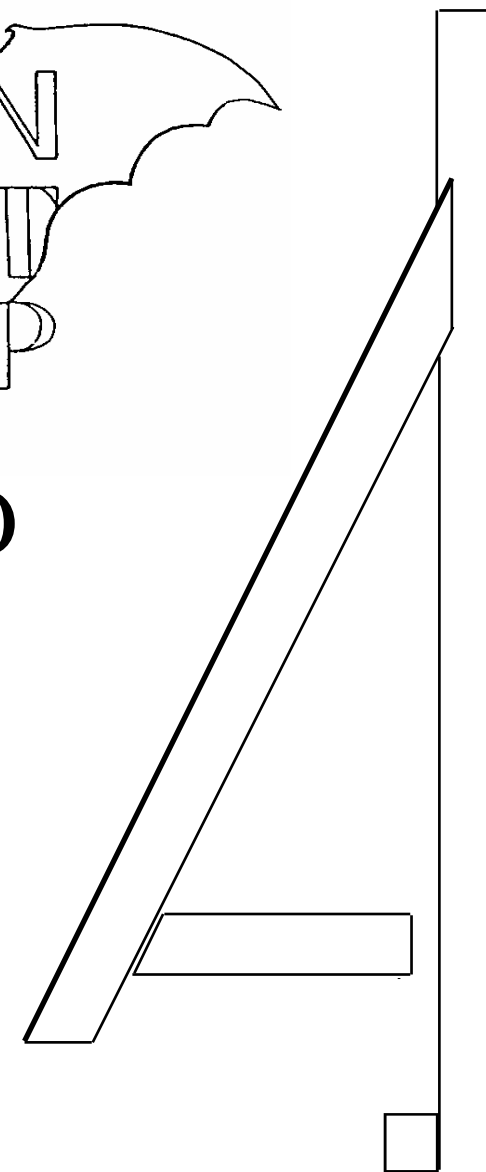

Removal of young, mature and decaying trees means many natural roost sites have been lost. Bat boxes cannot replace natural tree roosts, however they can provide an artificial alternative. Bat boxes can also be used by licensed bat workers to monitor bat populations. A bat box made from untreated timber can provide many years of good service.

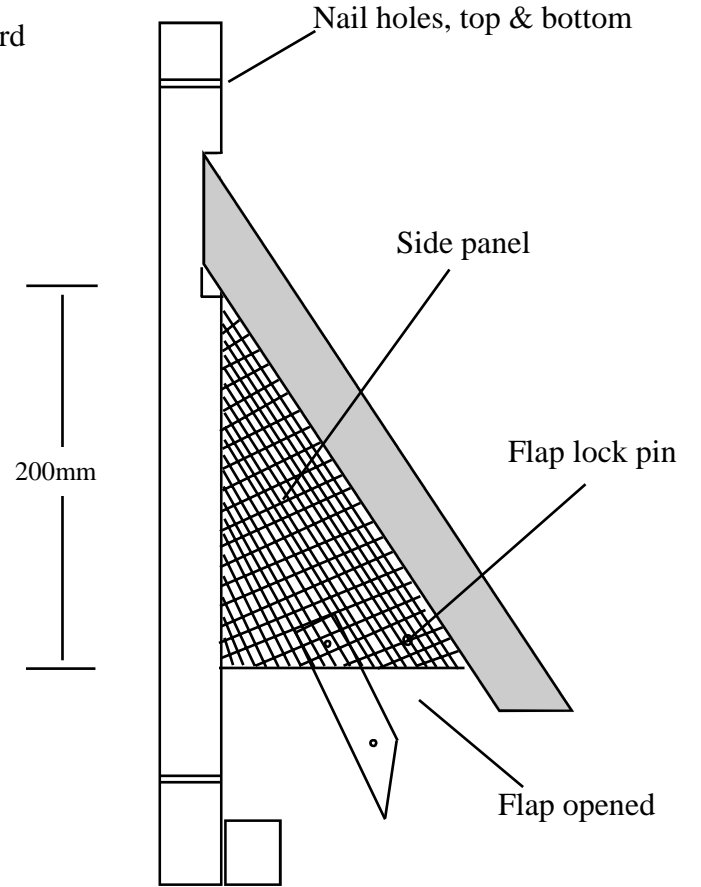
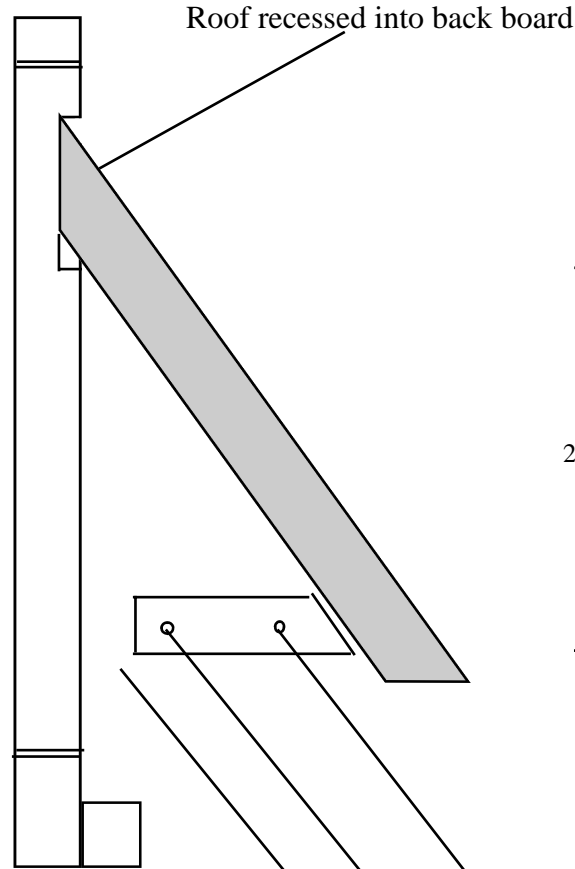
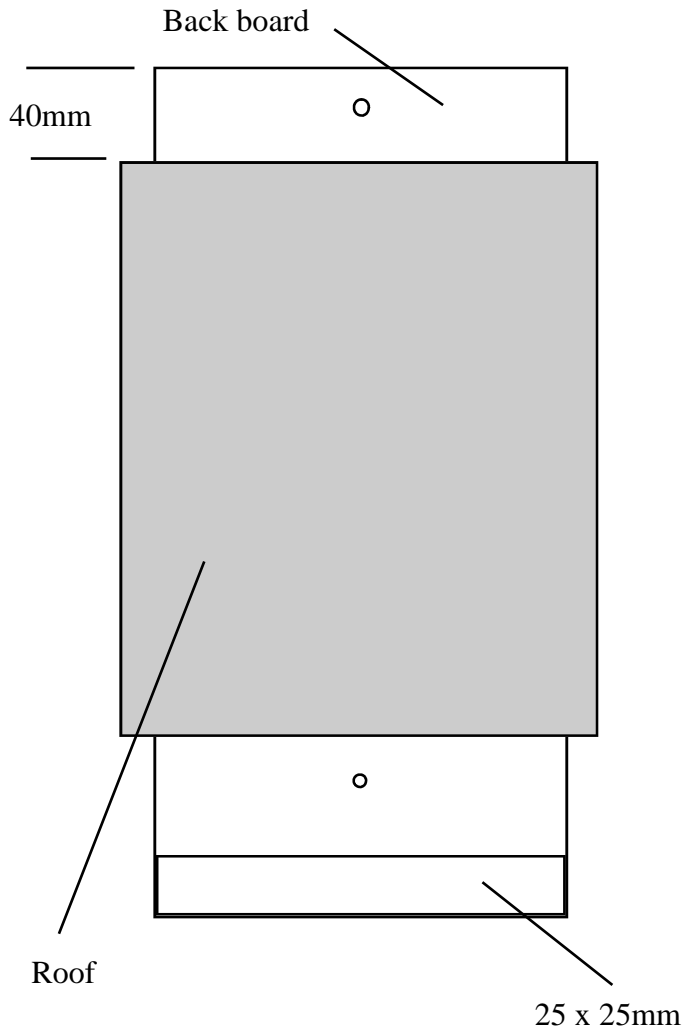

All wood to be sawn & untreated.  
Secure to trees using copper or aluminium alloy nails.

**Roof** 330 x 200mm. **Back board** 450 x 150mm. **Ledge** 25 x 25 x 150mm. **Flap** 100 x 130mm.  
**Side panel** 200 x 150mm Qty two.

Measurements are for 25mm thick wood. Assemble with galvanized nails and pre-drilled holes.

